

\*Dimension with cables at the end of the strokes

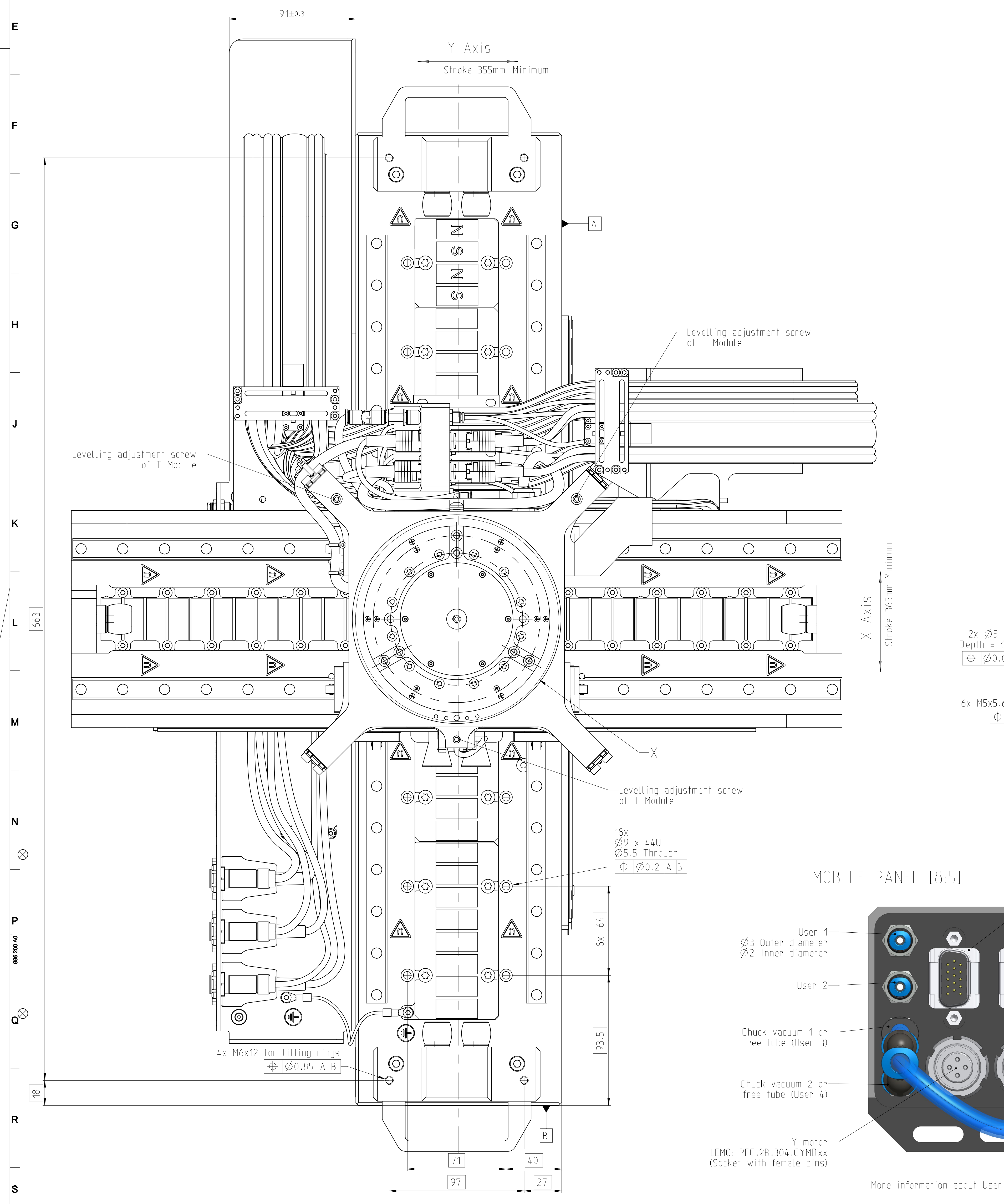

FRONT PANEL [6:5]

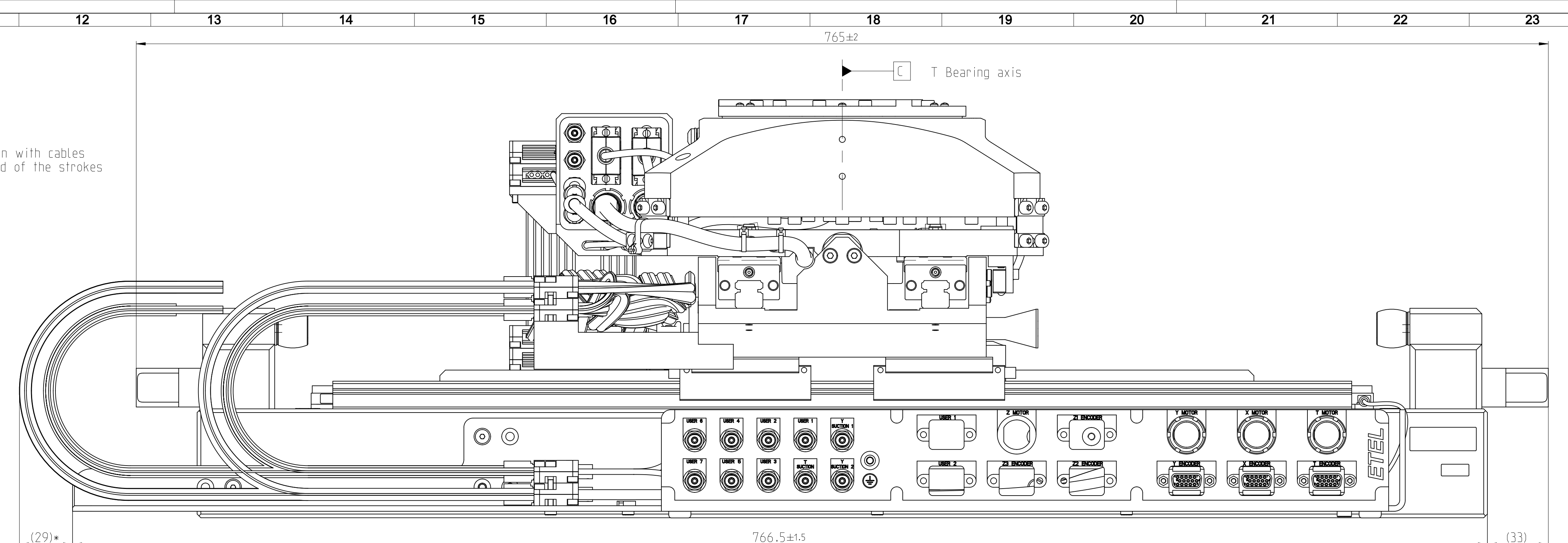
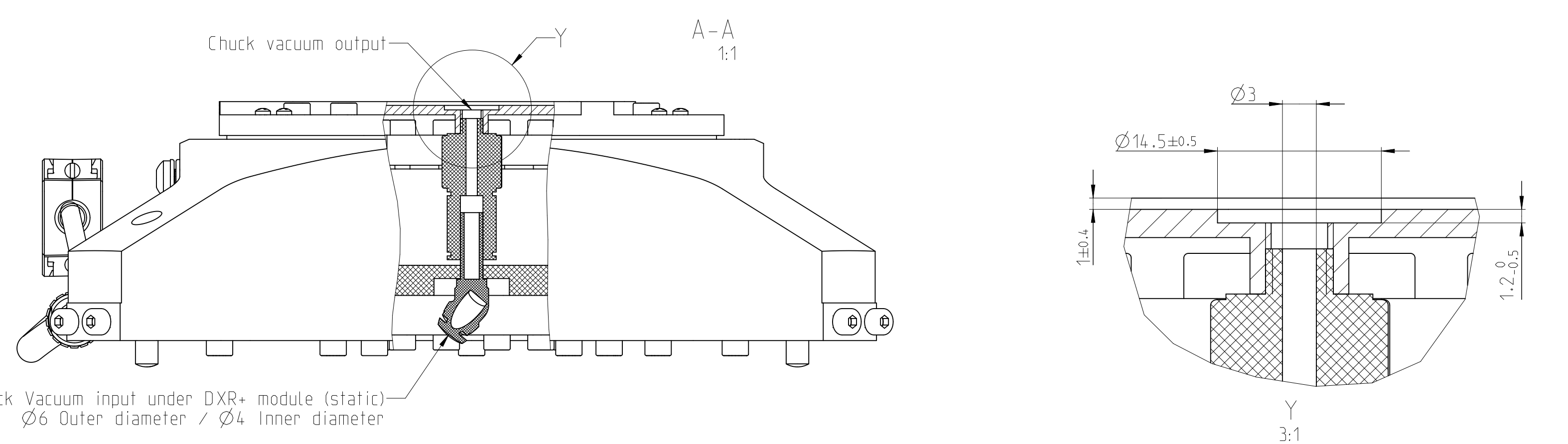
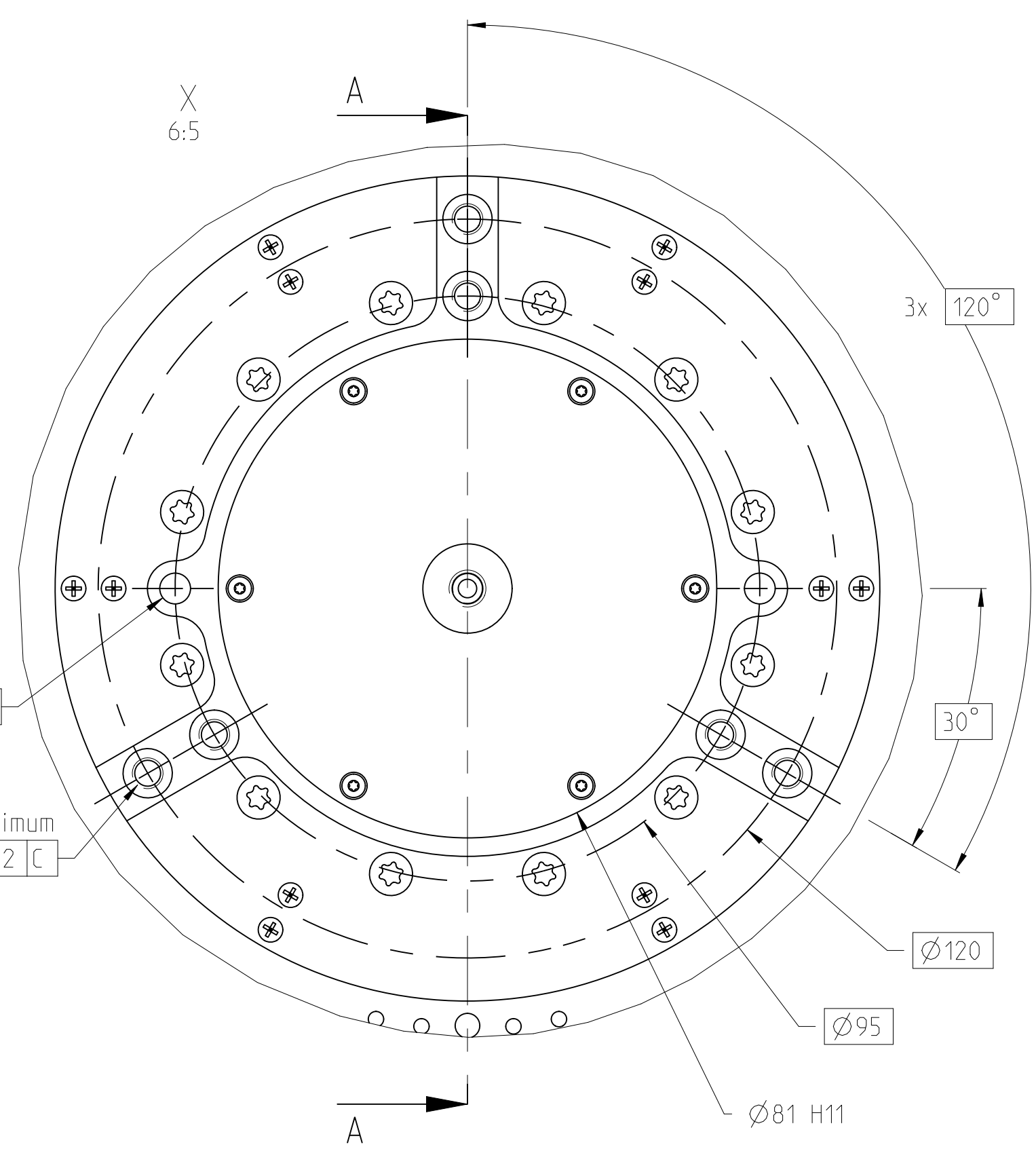
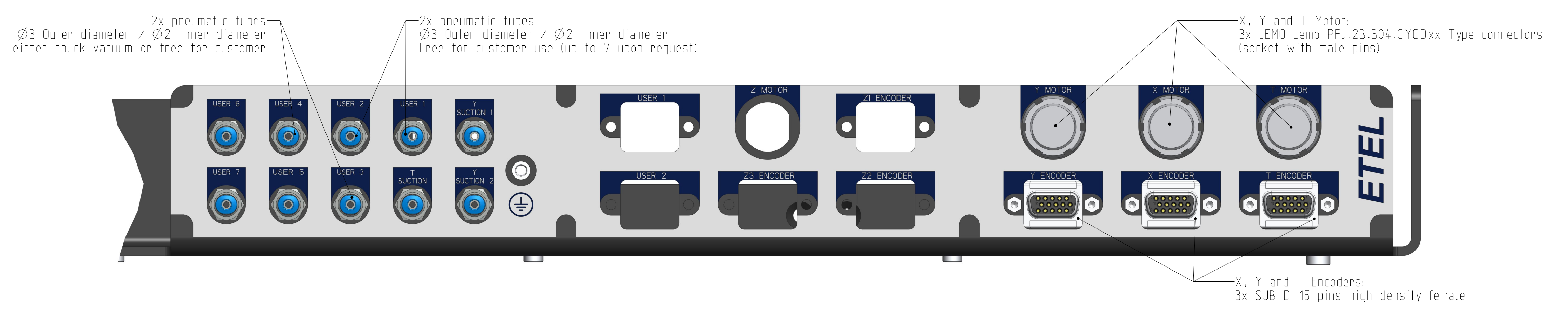

MOBILE PANEL [8:5]

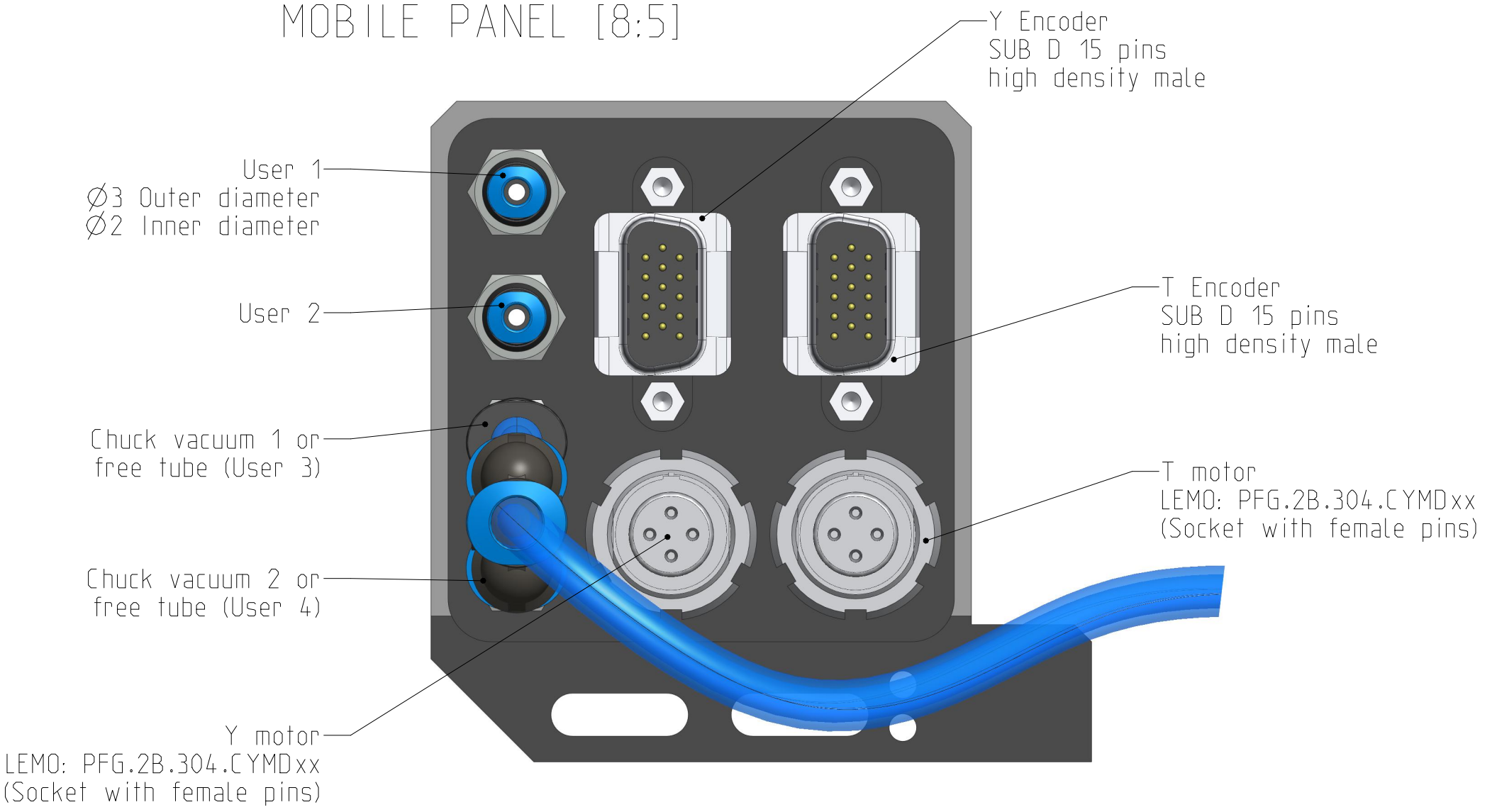

More information about User 5 to User 7 tubes upon request

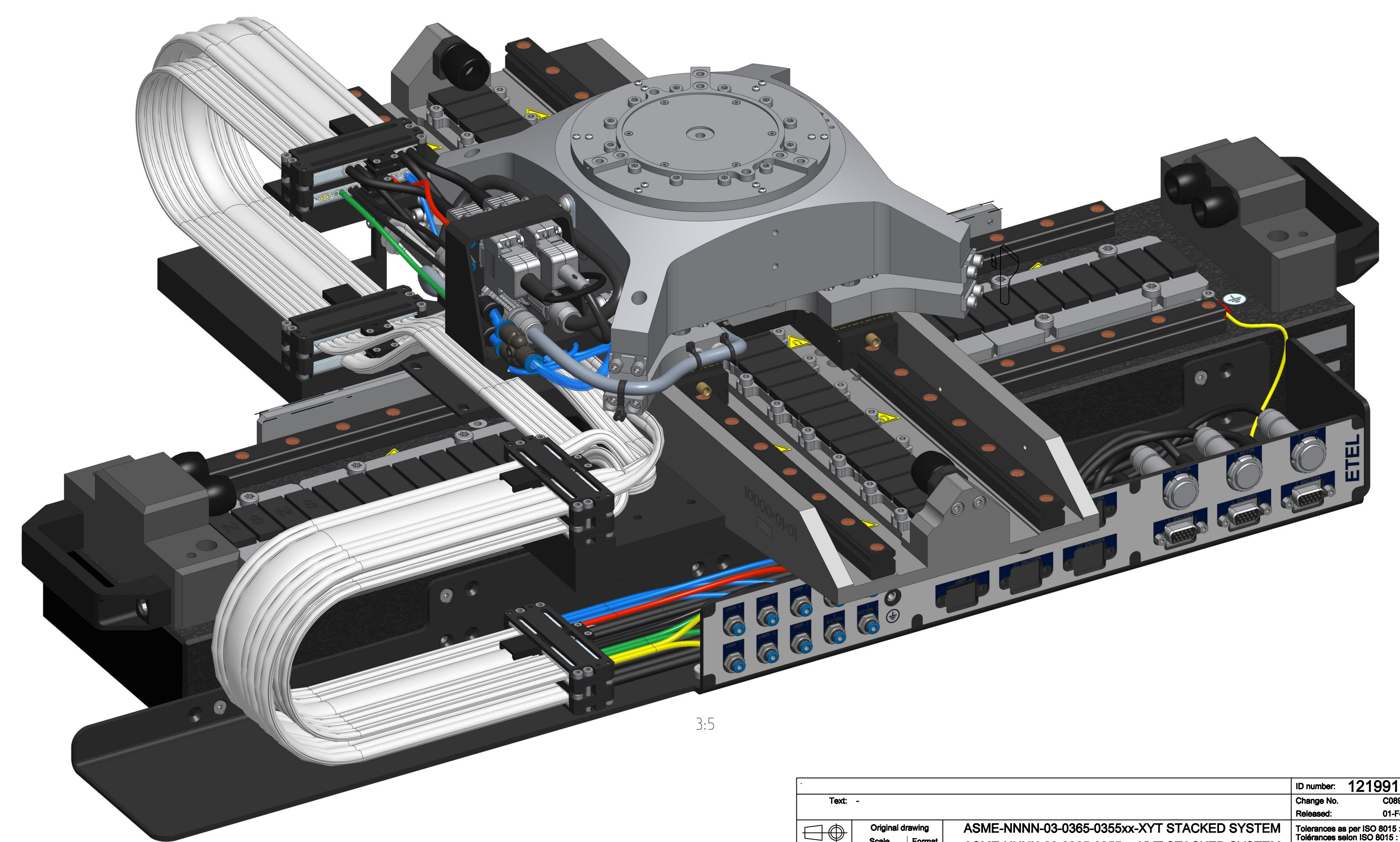

It is required to mount Charon 2 Stages on a granite or equivalent flat surface with a flatness inferior or equal to 3 microns

Title: _____		ID number: 1219919-01
Change No: 006023-04		Released: 01-Feb-19
Original drawing	ASME-NNNN-03-0365-0355xx-XYT STACKED SYSTEM	Tolerance as per ISO 8015:2011
Scale: 1/Format	ASME-NNNN-03-0365-0355xx-XYT STACKED SYSTEM	Tolerance as per ISO 8015:2011
Dimensions in mm: 7:10 AO	Making Dimensions / Cross-Reference	Dimensions without tolerance
The reproduction, distribution and utilization of this document as well as the communication of its contents to others without express authorization is prohibited. Offenders will be held liable for the payment of damages. All rights reserved in the event of the grant of a patent, utility model or design. (ISO 16016)		Dimensions with tolerance
ETEL S.A. 2112 Mollat SWITZERLAND		Version / Revision / Sheet: Page 1 of 1
1219923-02-A-01		Document number